

Time: 3 Hours

Marks: 80

- (1) Question No. 1 is compulsory.
- (2) Attempt any three questions from the remaining five questions.
- (3) Assume suitable data if needed.

**Q1. Attempt any four** **20**

- a. Explain various criteria for selecting a transducer for an application.
- b. What is a compensator? State its types and explain any one in detail.
- c. Given the transfer function  $T(s) = \frac{36}{s^2 + 4.2s + 36}$ , find the damping factor and natural frequency of the system. Find the response of the system when a unit step is applied.
- d. Draw Schering bridge circuit and derive formula for unknown parameters.
- e. What is the correlation between time domain and frequency domain characteristics?
- f. Explain the use of Nyquist stability criterion.

**Q2 Answer the following** **20**

- a. Using Routh's stability criterion, comment on the stability of the given system, having the characteristic equation  $s^6 + 2s^5 + 8s^4 + 12s^3 + 20s^2 + 16s + 16 = 0$ .
- b. Using block diagram reduction techniques, find closed loop transfer function  $C(s)/R(s)$  :

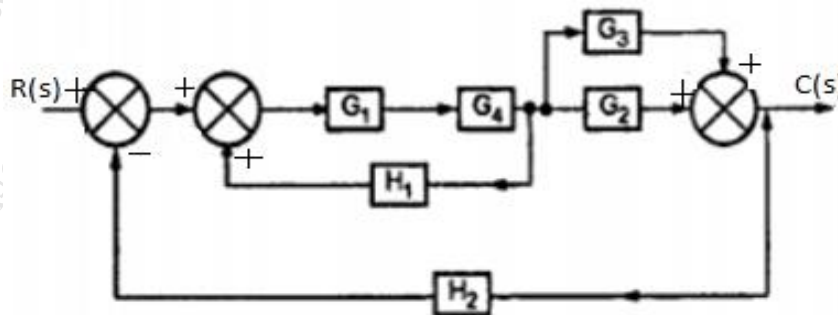

**Q3 Answer the following** **20**

- a. What is the use of Kelvin's double bridge? Explain Kelvin's double bridge with a neat diagram.
- b. Explain various types of errors in the measurement system.

**Q4. Answer the following** **20**

- a. For a unity feedback system having open loop transfer function  $G(s) = \frac{20(s+4)}{s(s+1)(s+2)}$ , find steady state error and error constants for applied step, ramp and parabolic inputs.
- b. For the given unity feedback system  $G(s)H(s) = \frac{k}{s(s+4)(s^2+4s+20)}$ . Sketch the root locus and comment on the system stability.

**Q5. Answer the following** **20**

- a. Draw Bode plot for a unity feedback control system with open loop transfer function  $G(s) = \frac{75(s+1)}{s(0.2s+1)(5s+1)}$ . Also find gain margin and phase margin.
- b. Sketch polar plot of  $G(s) = \frac{1}{(s+2)(s+4)}$ .

**Q6. Answer the following** **20**

- a. Obtain transfer function  $V_c(s)/V(s)$  of the following system :

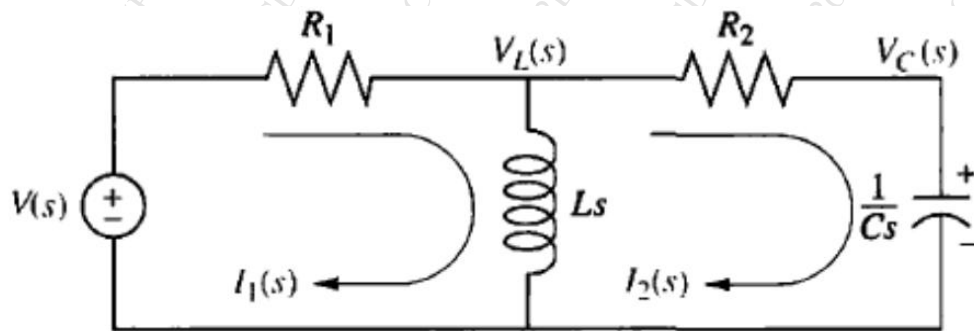

- b. Obtain transfer function  $C(s)/R(s)$  of the system using signal flow graph :

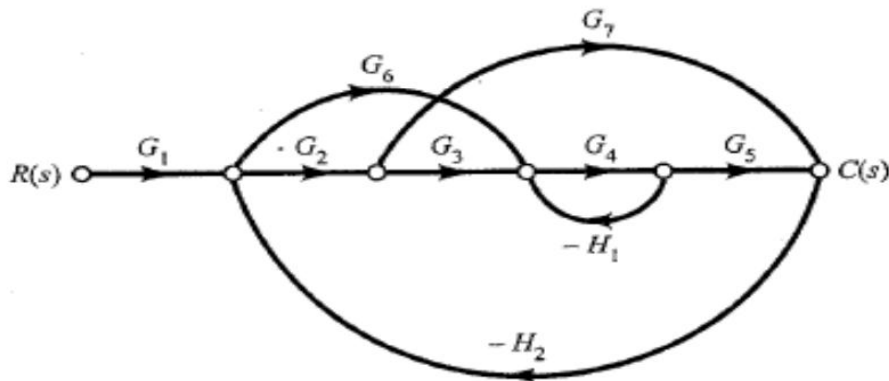

\*\*\*\*\*